

# O'HAGIN STANDARD AND O'HAGIN **FIRE & ICE** ATTIC VENTS

## INSTALLATION INSTRUCTIONS FOR COMPOSITION SHINGLE, SHAKE AND SLATE (NATURAL/SYNTHETIC) ROOF APPLICATIONS

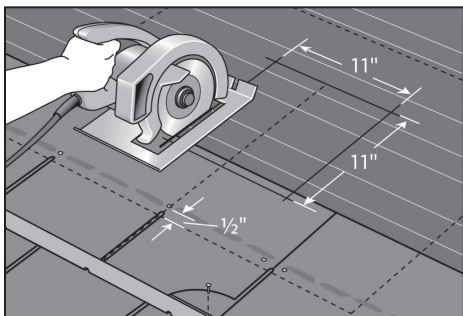

**1. MARK & CUT\*** Align front of vent 1/2 inch below nail line and mark outline of vent for placement later. Mark outline of 11 x 11 inch hole. With blade set to thickness of sheathing, cut hole in roof deck.

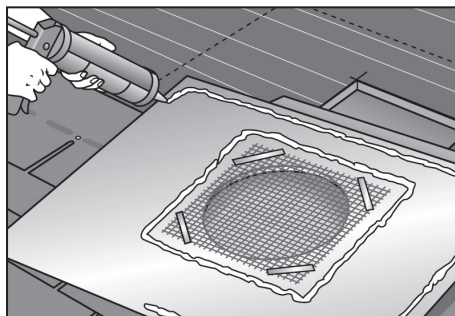

**2. SEAL** using a sufficient amount of locally-approved sealant (Class A where required by code for flame and ember resistance) around inner and outer flange.

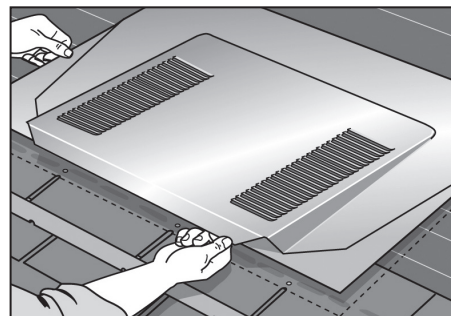

**3. PLACE** vent directly over 11 x 11 inch hole using previously marked outline as a guide.

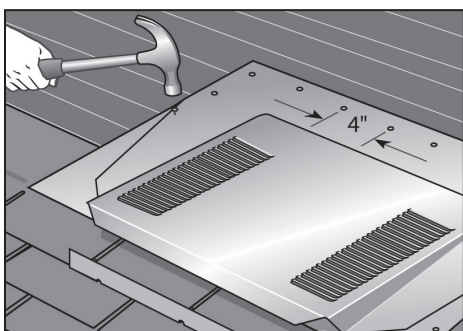

**4. SECURE** at 4 inch centers, using locally-approved roofing nails or screws of sufficient length to penetrate sheathing. **SEAL** all penetrations using locally-approved sealant (Class A where required by code for flame and ember resistance).

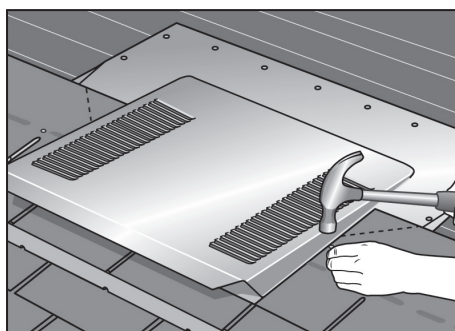

**5. COVER** with roofing material around vent. Based on local best practices, a 45 degree angle cut must be made on the material terminating at the vent. (See Step 5A if installing shingle-over finish method).

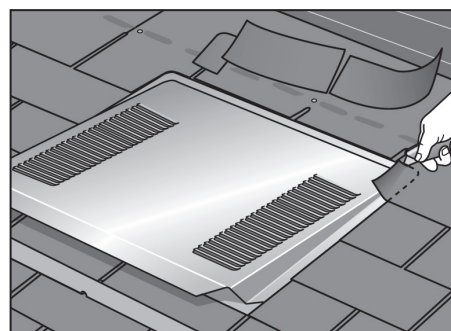

**6. TRIM** roofing material back 1 inch on top and sides of vent cover to allow for proper drainage.

### 5A. ALTERNATE SHINGLE-OVER FINISH METHOD

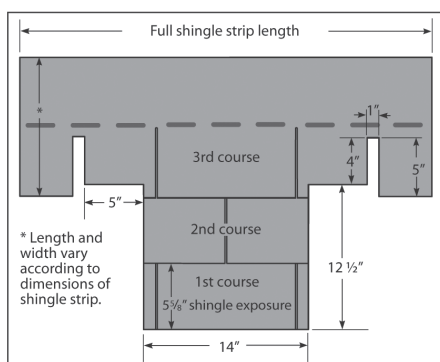

**1. TRIM** Cut 2 shingle strips to lengths shown for Courses 1 and 2. Using a full length of shingle strip, trim to pattern dimensions shown for Course 3.

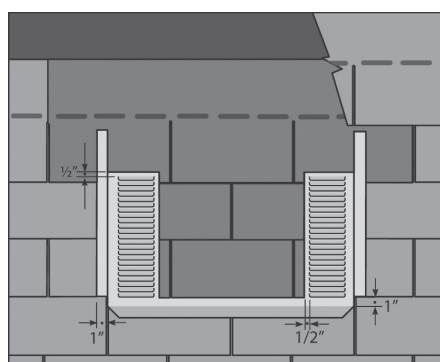

**2. BEGINNING WITH COURSE 1** Align and attach to top of vent as shown using locally-approved peel and stick, two-sided tape, or sealant (Class A where required by code for flame and ember resistance). Repeat with courses 2 and 3 to complete shingle-over finish method.

\***Optional Wind Diverter** (Wind speeds between 70-110 mph) installation should occur before securing lower course of shingles at vent placement. Mark diverter location (centered in alignment with vent location) one course below lower edge of vent. Apply bead of locally-approved sealant (Class A where required by code for ember and flame resistance) to underside of diverter; install on mark so that next shingle course can be installed over base of diverter, leaving 1/4 inch to 1/2 inch channel between edge of shingle course above diverter and inside diverter wall. Secure with four evenly-spaced, locally-approved roofing nails or screws of sufficient length to penetrate sheathing. Continue with Step 1.

### GENERAL INSTRUCTION NOTES:

- Class A materials should be used on installation of **FIRE&ICE**® attic ventilation products where required by local code.
- Do not install vents below areas of concentrated water runoff, particularly if partially under, near, or adjacent to solar array installations. Placement assumes gutters are installed and are in good working order in all applicable areas.
- Standard installation is at 3:12 pitch or greater.
- All low vents (intake) shall be uniformly installed a minimum of 6 inches above attic insulation. The width of any eave overhang must be taken into consideration so, for example, the insulation does not block the attic vent opening.
- All high vents (exhaust) shall be uniformly installed 2 to 3 courses below the ridge assembly, unless prevented by structural framing or other design limitations.
- O'Hagin vents are designed to be part of a complete roofing system. Failure to properly install all components will negatively impact overall performance and will void warranty protection.
- For specific information regarding high velocity wind areas (70-110 mph) contact O'Hagin.

210 Classic Court, Suite 100  
Rohnert Park, CA 94928  
Toll Free 877-324-0444  
Fax 707-588-918  
[www.ohagin.com](http://www.ohagin.com)

**O'HAGIN**   
THE TECHNOLOGICAL LEADER IN ATTIC VENTILATION



### WATCH OUR INSTALL VIDEOS

Scan this QR Code with your smart phone to watch easy step-by-step install videos.